

SP1

Issue 5
July 2001



"A Commitment to Quality"



Certificate No. 890217

**TYPE SPMA AND MA RANGE
OF AIR HANDLING UNITS**

INTRODUCTION

Type SPMA and Type MA Modular Aluminium Air Handling Units

This range of air handling units has primarily been designed as an economical, fast build alternative to units having welded steel frames, and offers significant reductions in weight, without losing inherent strength, coupled with good aesthetics and a maintenance free finish.

Units are of anodised, extruded aluminium framework construction with double skinned insulated panels offering good thermal properties and maximum sound reduction through the casings. Special purpose built designs are available on request.

Capacity

The range covers thirty one standard sizes from 0.2m³/s to 31.0m³/s. Non-standard sizes are also available to suit site limitations or where access is limited.

Selection

Selection is usually dependent on coil velocity. Four duties are listed for each unit; 2.0m/s and 2.5m/s for cooling applications, 3m/s and 3.5m/s for general ventilation applications.

Arrangements

Units are generally supplied in sections, upto 3.0 metres in length, for joining on site (by others). Units can be supplied, at additional cost, in smaller sections or in broken down form to suit site conditions.

Unit Support/Lifting Points

Units are supplied with 125mm or 150mm high base frames attached running longitudinally and transversely on larger units.

These frames are provided with lifting points which should always be used when hoisting units.

(For further recommendations on lifting units see Dalair's Installation & Maintenance Service Manual, available on request).

Mounting

Units can be arranged for vertical or horizontal airflow, double deck or side by side arrangements and are suitable for internal or external applications.

External units are supplied with a plastic coated sheet steel weather roof.

Contents	Page
INTRODUCTION	1
Capacity, Selection, Arrangements, Unit Support/Lifting Points & Mounting	
CONSTRUCTION SPECIFICATION	2
Framework, Enclosure & Access Panels, Leakage Standard	
COMPONENTS	2,3
Fans, Motors, Dampers, Coils, Electric Heaters, Gas Heaters, Filters, Humidification	
SELECTION DATA	4
SECTION LENGTHS	5
UNIT MOUNTED SILENCER SELECTION	6

CONSTRUCTION SPECIFICATION

SPECIFICATION

Framework

SPMA and MA50 units are constructed from anodised aluminium, extruded section, 30mm and 50mm wide respectively.

Corners are plastic or die-cast aluminium, of natural finish, and are rivet fitted within the framework.

Enclosure Panels

Construction of all panels is double skin of tray form, riveted, internally stiffened and with insulation encapsulated within.

Gauges of materials for panel construction are 1.0mm plastisol faced, mild steel outer and 0.7mm natural mild steel inner.

SPMA units have 25mm thick panels insulated with 45kg/m³ foam.

MA50 units have 50mm thick panels insulated with 45kg/m³ foam.

Alternative types of insulation such as mineral wool can be used.

Standard outer colours would be Ocean Blue (BS18C39) Goosewing Grey (BS10A05) or Moorland Green (BS12B21).

Full tested acoustic data for all Dalair's panels are available as undertaken and certified at the National Engineering Laboratory, East Kilbride.

Access Panels

Access panels are manufactured to the same specification as the enclosure panels and are fitted with cam action, quick release handles.

Doors close onto compression rubber seals to provide an airtight enclosure.

Panel Options

- Alternative panel materials and finishes
- Alternative panel insulation materials, e.g. rockwool or barrier mat

Leakage Standard

These units are suitable for Class A, B, or C as per DW143 and DW 144 leakage standards when measured in accordance with the HVAC guide to leakage testing of air handling units.

Unit Weights

Nominal unit weights can be calculated using the following formula:

MA: Unit Surface Area x Factor 60kg/m²

SPMA: Unit Surface Area x Factor 55kg/m²

For confirmation of actual unit weights and dimensions please refer to your regional Dalair sales office.

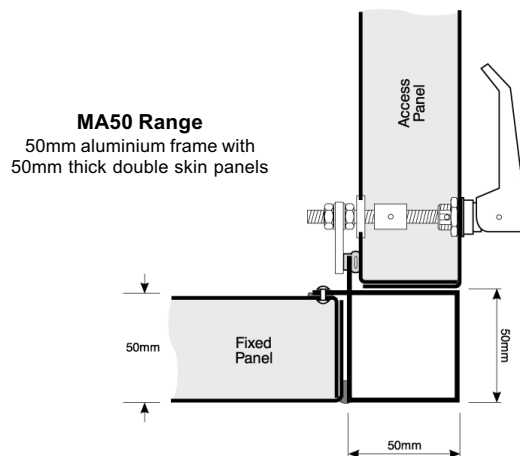
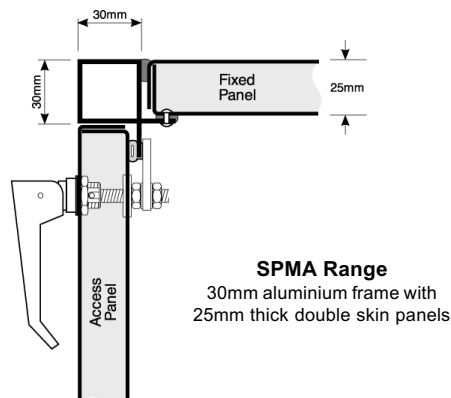

COMPONENTS

Fans

Fan sections are generally fitted with double inlet, double width, centrifugal fans with either forward or backward curved impellers.

Belt driven fans are fitted as standard, although direct driven fans are also available.

Belt driven fan and motor assemblies are mounted on fabricated section bases isolated from the unit casing with high performance spring or rubber anti-vibration mountings.

Flexible connections are fitted to the fan aperture.

Options

- Anti-spark track
- Fan inlet guards
- Drive guards (door guards on smaller units)
- Drain plug
- Inspection cover in fan scroll
- Anti-corrosive finishes

COMPONENTS

Motors

Unless otherwise specified motors would be single speed, 4 pole, foot mounted, totally enclosed fan cooled (TEFC) suitable for operation on a 415Volt / 3 Phase/50Hz electrical supply.

Motors are mounted on specially designed adjustable bases which facilitate easy tensioning of the belts without misalignment.

Options

- Alternative electrical supplies
- Run & stand-by facility
- Two speed and inverter speed controlled options
- Motors out of the airstream
- Motors wired to terminal boxes or electrical isolators
- Flameproof motors
- Energy efficient motors

Dampers

Dampers are constructed using either opposed or parallel action blades. They would be suitable for manual operation or supplied with an extended spindle for motorisation (motor by others).

Options

- Steel, aluminium or stainless steel construction
- Edge, tip or both edge and tip seals
- Protective finishes

Coils

All coils are constructed from 13mm or 16mm seamless copper tube mechanically bonded to plate type fins to provide a good mechanical and thermal bond.

All coils are inspected after manufacture and are subjected to an air under water test.

Coils are fitted within unit sections on base slides. Return bends and coil headers are fully encased within the unit and top and side baffle plates are fitted to prevent air by pass.

Where coil connections penetrate the unit casing, neoprene seals and capping plates are fitted.

Options

- Plain copper tube frost coils
- Aluminium, copper, steel, polyester coated aluminium or stainless steel fins
- Galvanised or stainless steel casework
- Electro-tinned finishes
- Removable drain trays
- Moisture eliminators
- Hospital "washdown" sections

Electric Heaters

Supplied with open or sheathed incoly elements, pre-wired with each step of control being brought back to a separate terminal block. (Or suitable for thyristor control by others)

Gas Heaters

Gas burners are fully automatic and meet all relevant British and Gas Safety Standards.

They are supplied with flame failure protection, manual reset overheat protection and gas train, complete with all necessary safety controls, and terminated with BSP connections.

For externally mounted air handling units, the gas train and controls are enclosed within a weatherproof housing.

Burners are supplied as standard suitable for on/off control.

Options

- Direct or indirect firing
- High/low burner
- Modulating or pulse control burner
- Stainless steel heat exchanger
- On-site commissioning

Filters

A wide choice of filters to suit virtually every application can be incorporated into the units.

Filters comply with Eurovent, ASHRAE or British Standards for dust arrestance, gravimetric efficiency and odour absorption.

Each filter supplied with a loose inclined gauge manometer for fitting on site (by others).

Filter selections are generally based on standard 594 x 594 or 594 x 297mm sizes and are selected against mean filter conditions.

Filters can be supplied for front or side withdrawal, although Dalair make the following recommendations :-

Side withdrawal :-

Filters up to and including 3.0 wide

Front withdrawal :-

Filters 3.5 cells wide and over, EU8 grade (and above),

bag filters and absolute filters.

Humidification

Humidifier sections are supplied in either stainless steel or smooth plastic lined sections.

A "fixed" stainless steel drain pan is incorporated into the base of the section and a double glazed viewing window is provided in the access door.

For externally mounted air handling units, the generator unit or steam trap/separating chamber are enclosed in a weatherproof housing.

Options

- Electric self generating type humidifier
- Direct steam injection type humidifier
- Compressed air/water nozzle system
- Ultrasonic
- Staged or proportional control
- Evaporative

SELECTION DATA

MODEL REF.	UNIT W x H (mm)	No. COILS	COIL W x H (mm)	COIL AREA (m ²)	Volume m ³ /s				FILTERS W x H
					Coil Velocity m/s				
					2.0	2.5	3.0	3.5	
SPMA 1	800 x 800	1	550 x 508	0.279	0.56	0.70	0.84	0.98	1.0 x 1.0
SPMA 2	1100 x 800	1	800 x 508	0.40	0.81	1.02	1.22	1.42	1.5 x 1.0
SPMA 3	1400 x 800	1	1100 x 508	0.55	1.12	1.40	1.68	1.96	2.0 x 1.0
SPMA 4	1100 x 1100	1	800 x 813	0.65	1.30	1.63	1.95	2.28	1.5 x 1.5
SPMA 5	1400 x 1100	1	1100 x 813	0.89	1.79	2.24	2.68	3.13	2.0 x 1.5
SPMA 6	1700 x 1100	1	1350 x 813	1.09	2.19	2.74	3.29	3.84	2.5 x 1.5
SPMA 7	2000 x 1100	1	1650 x 813	1.34	2.68	3.35	4.02	4.69	3.0 x 1.5
SPMA 8	1400 x 1400	1	1100 x 1117	1.22	2.46	3.07	3.68	4.30	2.0 x 2.0
SPMA 9	1700 x 1400	1	1350 x 1117	1.58	3.02	3.77	4.52	5.28	2.5 x 2.0
SPMA 10	2000 x 1400	1	1650 x 1117	1.84	3.69	4.61	5.53	6.45	3.0 x 2.0
SPMA 11	2300 x 1400	1	1950 x 1117	2.17	4.36	5.45	6.53	7.62	3.5 x 2.0
SPMA 13	1700 x 1700	1	1350 x 1422	1.92	3.84	4.80	5.76	6.72	2.5 x 2.5
SPMA 14	2000 x 1700	1	1650 x 1422	2.34	4.69	5.87	7.04	8.21	3.0 x 2.5
SPMA 15	2300 x 1700	1	1950 x 1422	2.77	5.55	6.93	8.32	9.71	3.5 x 2.5
SPMA 18	2000 x 2000	1	1650 x 1626	2.68	5.37	6.71	8.05	9.39	3.0 x 3.0
MA 1	800 x 800	1	500 x 508	0.25	0.51	0.64	0.76	0.89	1.0 x 1.0
MA 2	1100 x 800	1	750 x 508	0.38	0.76	0.95	1.14	1.33	1.5 x 1.0
MA 3	1400 x 800	1	1050 x 508	0.53	1.07	1.33	1.60	1.87	2.0 x 1.0
MA 4	1100 x 1100	1	750 x 812	0.60	1.22	1.52	1.83	2.13	1.5 x 1.5
MA 5	1400 x 1100	1	1050 x 812	0.85	1.70	2.13	2.56	2.98	2.0 x 1.5
MA 6	1700 x 1100	1	1300 x 812	1.05	2.11	2.64	3.17	3.69	2.5 x 1.5
MA 7	2000 x 1100	1	1600 x 812	1.29	2.60	3.25	3.90	4.55	3.0 x 1.5
MA 8	1400 x 1400	1	1050 x 1117	1.17	2.35	2.93	3.52	4.11	2.0 x 2.0
MA 9	1700 x 1400	1	1300 x 1117	1.45	2.90	3.63	4.36	5.08	2.5 x 2.0
MA 10	2000 x 1400	1	1600 x 1117	1.78	3.57	4.47	5.36	6.25	3.0 x 2.0
MA 11	2300 x 1400	1	1900 x 1117	2.12	4.24	5.31	6.37	7.43	3.5 x 2.0
MA 12	2600 x 1400	1	2200 x 1117	2.45	4.91	6.14	7.37	8.60	4.0 x 2.0
MA 13	1700 x 1700	1	1300 x 1422	1.84	3.70	4.62	5.54	6.47	2.5 x 2.5
MA 14	2000 x 1700	1	1600 x 1422	2.27	4.55	5.69	6.83	7.96	3.0 x 2.5
MA 15	2300 x 1700	1	1900 x 1422	2.70	5.40	6.76	8.11	9.46	3.5 x 2.5
MA 16	2600 x 1700	1	2200 x 1422	3.12	6.26	7.82	9.38	10.95	4.0 x 2.5
MA 17	3200 x 1700	1	2800 x 1422	3.98	7.96	9.95	11.94	13.93	5.0 x 2.5
MA 18	2000 x 2000	1	1600 x 1626	2.60	5.20	6.50	7.80	9.10	3.0 x 3.0
MA 19	2300 x 2000	1	1900 x 1626	3.08	6.18	7.72	9.27	10.81	3.5 x 3.0
MA 20	2600 x 2000	1	2200 x 1626	3.57	7.15	8.94	10.73	12.52	4.0 x 3.0
MA 21	3200 x 2000	1	2800 x 1626	4.55	9.11	11.38	13.66	15.94	5.0 x 3.0
MA 22	3800 x 2000	2	1600 x 1626	5.20	10.41	13.01	15.61	18.21	6.0 x 3.0
MA 23	2300 x 2300	1	1900 x 1930	3.66	7.33	9.17	11.00	12.83	3.5 x 3.5
MA 24	2600 x 2300	1	2200 x 1930	4.24	8.49	10.62	12.74	14.86	4.0 x 3.5
MA 25	3200 x 2300	1	2800 x 1930	5.40	10.81	13.51	16.21	18.91	5.0 x 3.5
MA 26	3800 x 2300	2	1600 x 1930	6.17	12.35	15.44	18.53	21.62	6.0 x 3.5
MA 27	2600 x 2600	1	2200 x 2287	5.03	10.08	12.58	15.09	17.61	4.0 x 4.0
MA 28	3200 x 2600	1	2800 x 2287	6.40	12.81	16.01	19.21	22.41	5.0 x 4.0
MA 29	3800 x 2600	2	1600 x 2287	7.31	14.64	18.30	21.95	25.61	6.0 x 4.0
MA 30	3200 x 3200	2	1300 x 2845	7.39	14.79	18.49	22.19	25.89	5.0 x 5.0
MA 31	3800 x 3200	2	1600 x 2845	9.10	18.21	22.76	27.31	31.86	6.0 x 5.0

SECTION LENGTHS (mm)

WIDTH HEIGHT	800 800	1100 800	1400 800	1100 1100	1400 1100	1700 1100	2000 1100	1400 1400	1700 1400	2000 1400	2300 1400	2600 1400	1700 1700	2000 1700	2300 1700
2 Way Mixing Box	400	400	400	500	500	600	600	600	600	600	900	900	900	800	800
Panel Filter	350	350	350	350	350	350	350	350	350	350	350	350	350	350	350
Bag Filter	500	500	500	500	500	500	500	500	500	500	500	500	500	500	500
Heating Coil (2 Row)	350	350	350	350	350	350	350	350	350	350	350	350	350	350	350
Cooling Coil (8 Row)	600	600	600	600	600	600	600	600	600	600	600	600	600	600	600
Elimin- ators	200	200	200	200	200	200	200	200	200	200	200	200	200	200	200
Access Section	600	600	600	600	600	600	600	600	600	600	600	600	600	600	600
Fan Section	1000	1300	1300	1300	1300	1500	1500	1300	1500	1500	2000	2000	2000	2000	2000
Diffuser Section	500	500	500	600	600	600	750	600	750	750	1000	1000	1000	1000	1000
Humidifier Section	1000	1000	1000	1000	1000	1000	1000	1000	1000	1000	1000	1000	1000	1000	1000
1200mm Silencer	1200	1200	1200	1200	1200	1200	1200	1200	1200	1200	1200	1200	1200	1200	1200
1800mm Silencer	1800	1800	1800	1800	1800	1800	1800	1800	1800	1800	1800	1800	1800	1800	1800
Gas Heater	1300	1300	1300	1300	1300	1600	1600	1300	1600	1600	1600	1600	1600	1600	1600

See page 2 for unit weights information.

WIDTH HEIGHT	2600 1700	3200 1700	2000 2000	2300 2000	2600 2000	3200 2000	3800 2000	2300 2300	2600 2300	3200 2300	3800 2300	2600 2600	3200 2600	3800 2600	3200 3200	3800 3200
2 Way Mixing Box	900	1000	900	900	900	1100	1200	1000	1000	1200	1200	1100	1100	1200	1200	1300
Panel Filter	350	350	350	350	350	350	350	350	350	350	350	350	350	350	350	350
Bag Filter	500	500	500	500	500	500	500	500	500	500	500	500	500	500	500	500
Heating Coil (2 Row)	350	350	350	350	350	350	350	350	350	350	350	350	350	350	350	350
Cooling Coil (8 Row)	600	600	600	600	600	600	600	600	600	600	600	600	600	600	600	600
Elimin- ators	200	200	200	200	200	200	200	200	200	200	200	200	200	200	200	200
Access Section	600	600	600	600	600	600	600	600	600	600	600	600	600	600	600	600
Fan Section	2000	2000	2000	2000	2000	2000	2500	2000	2000	2000	2500	2500	2500	3000	3000	3000
Diffuser Section	1000	1200	1200	1200	1200	1300	1200	1200	1200	1300	1300	1300	1500	1500	1500	1500
Humidifier Section	1000	1000	1000	1000	1000	1000	1300	1000	1000	1300	1000	1000	1300	1000	1000	1300
1200mm Silencer	1200	1200	1200	1200	1200	1200	1200	1200	1200	1200	1200	1200	1200	1200	1200	1200
1800mm Silencer	1800	1800	1800	1800	1800	1800	1800	1800	1800	1800	1800	1800	1800	1800	1800	1800
Gas Heater	1600	1600	1600	2400	2400	2400	2400	2400	2400	2400	2400	2400	2400	2400	2400	2400

NOISE CRITERIA

The acoustic requirement for a silencer is determined from the system sound analysis. Selection is made from the appropriate silencer attenuation chart and must give the required attenuation or more in all octave bands. The air velocity through the silencer affects the pressure loss and noise regeneration. To prevent noise regeneration above the background level (as a guide only) do not exceed the maximum velocity stated in the table opposite.

- NR50 do not exceed 15m/s in silencer airway
- NR40 do not exceed 12m/s in silencer airway
- NR35 do not exceed 10m/s in silencer airway
- NR30 do not exceed 8m/s in silencer airway
- NR25 do not exceed 6m/s in silencer airway
- NR20 do not exceed 4m/s in silencer airway

Noise Criteria	Background noise levels (dB) at band centre frequencies (Hz)							
	63	125	250	500	1K	2K	4K	8K
NC70	83	79	75	72	71	70	69	68
NC65	80	75	71	68	66	64	63	62
NC60	77	71	67	63	61	59	58	57
NC55	74	67	62	58	56	54	53	52
NC50	71	64	58	54	51	49	48	47
NC45	67	60	54	49	46	44	43	42
NC40	64	57	50	45	41	39	38	37
NC35	60	52	45	40	36	34	33	32
NC30	5	48	41	35	31	29	28	27
NC25	54	44	37	31	27	24	22	21
NC20	51	40	33	26	22	19	17	16
NC15	47	36	29	22	17	14	12	11

Noise Level	Background noise levels (dB) at band centre frequencies (Hz)							
	63	125	250	500	1K	2K	4K	8K
NR70	91	83	77	73	70	68	66	64
NR65	87	78	72	68	65	62	61	59
NR60	83	74	68	63	60	57	55	54
NR55	79	70	63	58	55	52	50	49
NR50	75	65	59	53	50	47	45	43
NR45	71	61	54	48	45	42	40	38
NR40	67	57	49	44	40	37	35	33
NR35	63	52	45	39	35	32	30	28
NR30	59	48	40	34	30	27	25	23
NR25	55	44	35	26	25	22	20	18
NR20	51	39	31	24	20	17	14	13
NR15	47	35	26	19	15	12	9	7

Typical noise level requirements

NR Criteria	NC Criteria	Environment
NR55	NC55 - 65	Factories (Heavy Engineering)
NR50	NC45 - 55	Factories (Light Engineering)
NR45	NC40 - 50	Kitchens, Laundries, Computer rooms, Cafeteria, Canteens, Swimming pools.
NR40	NC35 - 40	Toilets, Receptions, Halls, Offices, Nightclubs, Large Restaurants, Department Stores, Gymnasiums, Laboratories.
NR35	NC30 - 35	Hospital wards, Museums, Libraries, Small Restaurants, Bars, Small Shops, Banks, Court Rooms.
NR30	NC25 - 30	Operating Theatres, Cinemas, Multipurpose Halls, Hotel Bedrooms, Conference & Lecture rooms (25-30 people)
NR25	NC20 - 25	Live Theatres (Upto 500 seats), Large Conference rooms (50+ people), Television Studios.
NR20	NC15 -20	Concert Halls, Opera Halls, Live Theatres (Above 500 seats), Sound Reproduction Studios.

Silencer quick selection guide, lengths in mm (Allow 100mm airways)

NC Criteria	Static Pressure (Pa)				
	375	750	1000	1250	1500
NR45	900	900	1200	1200	1500
NR40	900	1200	1500	1800	2100
NR35	1200	1500	1800	2100	2400
NR30	1800	2100	2100	2400	2400

NOTE: To be used as a quick selection guide only, for a full acoustic analysis contact Dalair Limited.
Secondary silencers may be required for NR30 or lower noise level.



Wednesbury Head Office



**AIR HANDLING
EQUIPMENT**

Head Office

*Southern Way, Wednesbury, West Midlands WS10 7BU
Telephone: 0121-556 9944 Fax: 0121-502 3124, 0121-505 2106
Email: sales@dalair.co.uk*

Northern Office

*Carrington Business Park, Manchester Road, Carrington, Manchester M31 4XL
Telephone: 0161-776 4045 Fax: 0161-776 2585
Email: manchester@dalair.co.uk*

Southern Office

*No 8 Churchill Court, 58 Station Road, North Harrow, Middlesex HA2 7SA
Telephone: 0208-861 3317 Fax: 0208-861 2357
Email: london@dalair.co.uk*



Local Agent/Representative/Distributor

*Due to our policy of continued improvements in both
design and performance, we reserve the right to alter
details without notification*